

Ceiling-mounted spotlight fitting

5905339073716

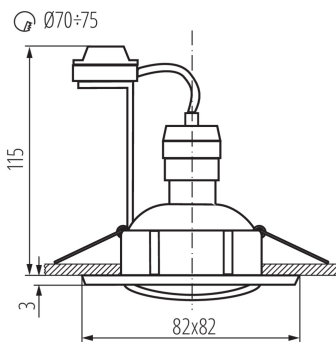

Kanlux TESON are simple eyes which will light up each room. You can choose a source of light and a version of the holder on your own - with adjustment or immovable.

GENERAL DATA:

Colour: aluminium

Necessity of using self-shielding lamps : yes

Place of assembly: Recessed mount in the ceiling

Place of application: Indoors

Minimum distance from the illuminated object : 0,5m

The product is not suitable to be installed on a normally flammable surface: >35W

The product is not suitable to be covered with a heat-insulating material: yes

Length [mm]: 83

Width [mm]: 83

Height [mm]: 24

Assembly hole [mm]: Ø70-75

TECHNICAL DATA:

Rated voltage [V]: 220-240 AC

Rated frequency [Hz]: 50

Maximum power [W]: max 10

Class of protection against electric shock : II

Light source: PAR16

Light source included: no

Cap: GU10

Ambient temperature range to which the product can be exposed: 5÷25

Enclosure material: aluminum alloy

Connection type: Bolt terminal block

Range of sections of wires used [mm²]: 0,75÷2,5

Lighting-fixture angle regulation : in one axis

Lighting-fixture angle regulation [°]: 30

IP class: 20

LOGISTIC DATA:

Unit of measurement: unit

Packaging method: 50

Number of units in the secondary packaging : 1

Number of units in the packaging: 50

Net unit weight [g]: 130

Grammage [g]: 168

07371 TESON AL-DTL50

Ceiling-mounted spotlight fitting



Weight of a cardboard box [kg]: 8.4

Width of a cardboard box [cm]: 25.5

Height of a cardboard box [cm]: 23

Length of a cardboard box [cm]: 53

Volume of a cardboard box [m³]: 0.031085